



SAMM 
ENGINEERS FOR GREENER SOLUTIONS

OIL SKIMMER

REMOVING TRAMP OIL FROM
COOLANTS & WASHING SOLUTIONS



We guarantee that every single unit individually tested through strict control procedure. Each unit is issued a test certificate for quality and function.

- ✓ COMPACT, PORTABLE & RUST PROOF
- ✓ EXTENDS COOLANTLIFE
- ✓ EASY TO INSTALL
- ✓ 415V/240V3PH50/60HZ
- ✓ APPLICABLE FOR VARIOUS WATER SOLUBLE CUTTING & GRINDING FLUIDS

OIL SKIMMER

REMOVING TRAMP OIL FROM COOLANTS & WASHING SOLUTIONS

The coolant, widely used in Grinding Machines as well as in CNC Machines migrates oil from lubrication spill out or leakages. This is called tramp oil and floats on the coolant surface. The tramp oil reduces functional efficiency of coolant and produces oil mist. OIL SKIMMER is a device designed to remove tramp oil floating on the coolant surface.

FEATURES:

- Compact, portable and rust proof.
- Easy to install.
- No maintenance.
- Belt type.
- 415 V / 240 V 3 ph 50 / 60 Hz.
- Side Mounted.
- Surface Mounted.

BENEFITS:

- Extends coolant life.
- Extends grinding wheel/tool life.
- Improves surface finish.
- Reduces formation of oil mist.

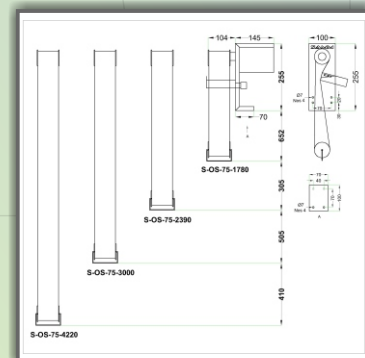
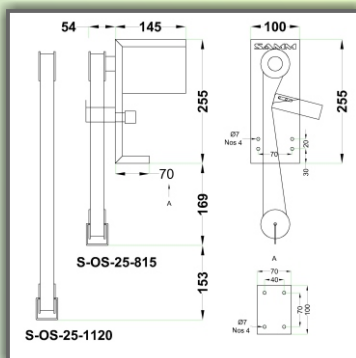

ALL BELTS ARE [25 MM] WIDE
CIRCUMFERENCE OF BELT

- S-Os-25-815mm.
- S-Os-25-1120mm.

ALL BELTS ARE [75 MM] WIDE
CIRCUMFERENCE OF BELT

- S-Os-75-1780mm.
- S-Os-75-2390mm.
- S-Os-75-3000mm.
- S-Os-75-4220mm.

SAMM MULTITECH

Plot No. 2408/5, GIDC Phase IV,
Near Delux Bearings,
Wadhwan - 363 035,
(Dist. Surendranagar-Gujarat-India.)
+91 99988 81449
samm.multitech@gmail.com | info@samm.co.in
www.samm.co.in

A VENTURE BY

